

In the figure shown, the capacitance is C and the inductance is L . The resistance in the top branch is R_t , and in the bottom branch is R_b . The potential of the power supply is V_{rms} .

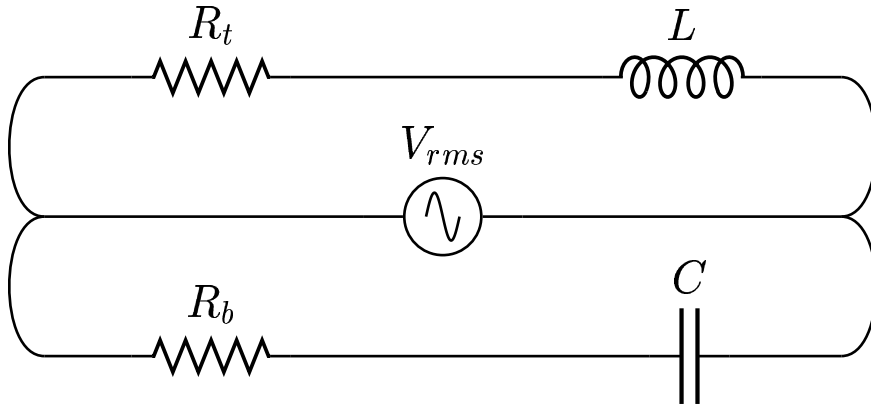

Find the rms current delivered by the power supply when the frequency is very small.

A) $I = \frac{V_{rms}}{R_t + R_b}$

B) $I = \frac{V_{rms}}{R_t}$

C) $I = \frac{V_{rms}}{R_b}$

D) $I = \frac{V_{rms} (R_t + R_b)}{R_t R_b}$

The impedance of the bottom and top branches is

$$Z_b = \sqrt{R_b^2 + \left(\frac{1}{\omega C}\right)^2} \quad \text{and} \quad Z_t = \sqrt{R_t^2 + (\omega L)^2}.$$

We notice that, when the frequency is very small, $\frac{1}{\omega C} \rightarrow \infty$ and $\omega L \rightarrow 0$. This means that the bottom branch, with very large impedance, carries negligible current; while the impedance of the top branch reduces to R_t . The current that flows in the power supply and the top branch is

$$I = I_t = \frac{V_{rms}}{Z_t} = \frac{V_{rms}}{R_t}.$$

Answer **B**.