

Consider the double slit experiment, where slit #1 is covered by a plastic with thickness t and index of refraction n . O' is where the phase difference of two rays shown is zero.

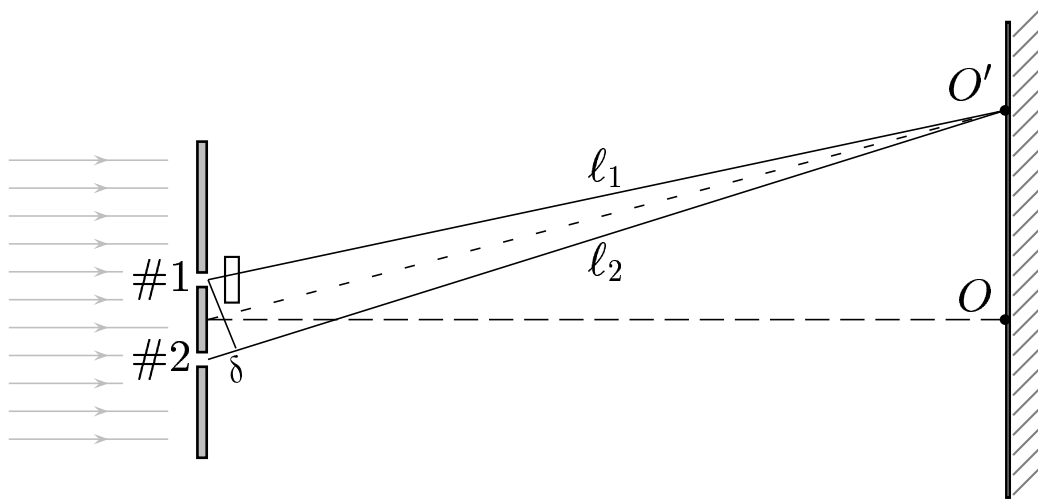

Given the extra phase due to the passage of the plastic

$$\phi_{med} = k t (n - 1) = 4.8 \pi.$$

Determine δ .

- A) $\delta = 1.2 \lambda$
- B) $\delta = 2.4 \lambda$
- C) $\delta = 4.8 \lambda$

$$k = \frac{2\pi}{\lambda} \Rightarrow \phi = k l_2 - (k l_1 + \phi_{med}) = k \delta - \phi_{med}.$$

From the given, $\phi = k \delta - \phi_{med} = 0$. This allows us to solve for δ , which leads to

$$\delta = \frac{\phi_{med} \lambda}{2\pi} = 2.4 \lambda.$$

Answer **B**.