

***Understanding process-dependent oxygen vacancies in thin  $\text{HfO}_2/\text{SiO}_2$  stacked-films on Si (100) via competing electron-hole injection dynamic contributions to second harmonic generation.***

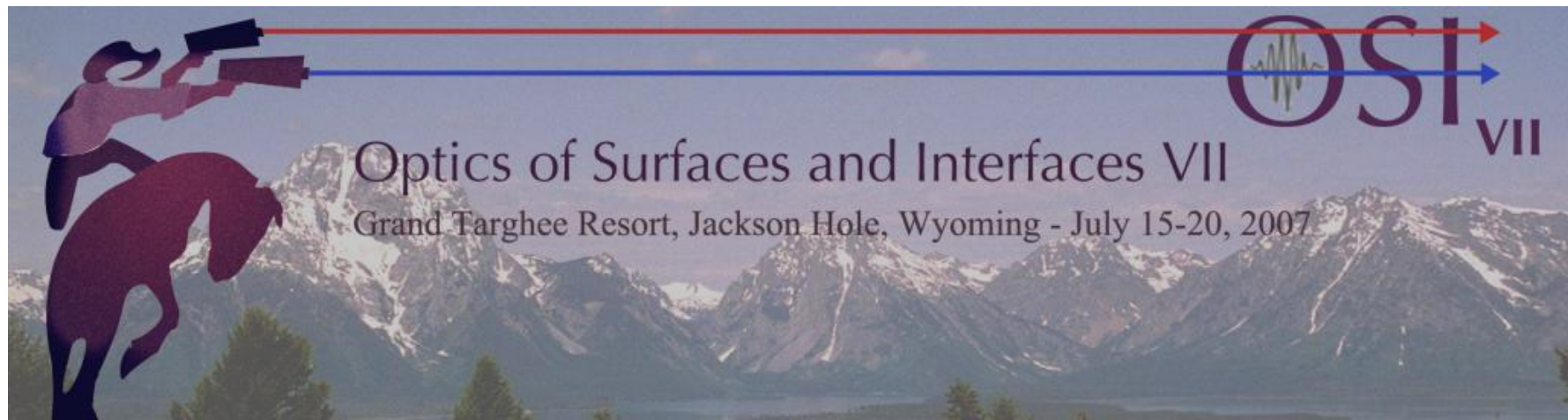

J. Price,<sup>1,2</sup> Y. Q. An,<sup>1</sup> M. C. Downer<sup>1</sup>

<sup>1</sup> The university of Texas at Austin, Department of Physics, Austin, TX

<sup>2</sup> SEMATECH, Austin, TX



## Abstract:

Optical Second Harmonic Generation (SHG) is used to characterize charge trapping dynamics in thin  $\text{HfO}_2$  films deposited on chemically oxidized P-type Si(100) substrates. Previous work identified Electrostatic Field Induced Second Harmonic (EFISH) generation as the dominant process-dependent contribution to the nonlinear response of such structures. EFISH generation was attributed to charges trapped primarily in oxygen vacancy defects located at the  $\text{SiO}_2/\text{HfO}_2$  interface that create an electrostatic field acting on the silicon space charge region. Here, we extend the understanding of charge trapping by monitoring SHG as  $\text{HfO}_2$  thickness and post-deposition anneal (PDA) temperature are modified. Corresponding trends in time-dependent SHG are identified that reflect unique contributions from competing electron and hole injection dynamics. Specifically, we attribute the initial increase in Time Dependent (TD) SHG intensity to photo-excited electrons from the silicon dominating the electrostatic field response. The subsequent decrease in SHG intensity corresponds to the resonant tunneling of hole carriers trapped at the interface and creating a larger field but biased in the reverse direction of the initial dipole field located at the interface. These results show that SHG can provide an *in situ*, non-destructive diagnostic of charge trapping in thin gate dielectric films.

## Key take-home points:

- TD SHG governed by both electron and hole injection dynamics:
  - Photo-excited electrons cause increase in SHG
  - Trap-assisted hole tunneling causes decrease in SHG
- Density of charge trapping defects in the gate dielectric will promote charge transfer and build up of interfacial electric field
- SHG provides the ability to qualitatively understand gate oxide and interface integrity due to charge trapping defects

# High- $k$ dielectric defects and device performance:

- **What are they? Anything that can trap charges.**
  - $O_2$ ,  $N_2$ , vacancies and / or interstitials.
  - Impurities (C, B, etc.).
  - Crystal imperfections (grain boundaries, surface states).
  - All are discrete localized states within the band gap.
- **How does this affect device performance?**
  - Degradation of carrier mobility.
  - Charge trapping.
  - increase in leakage current.

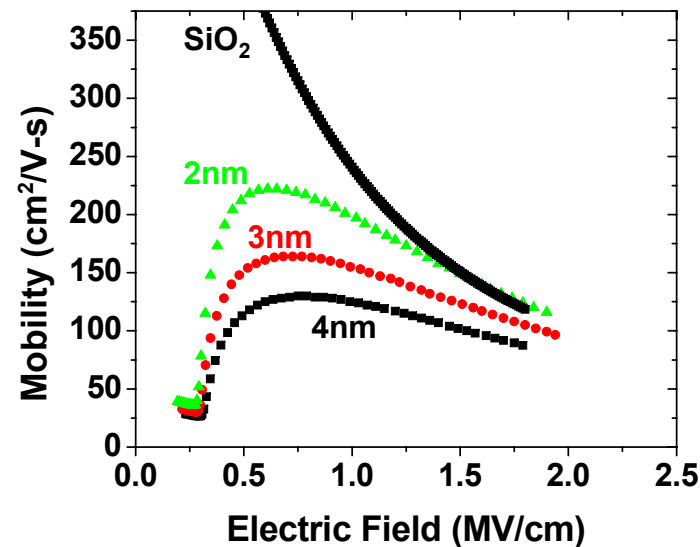
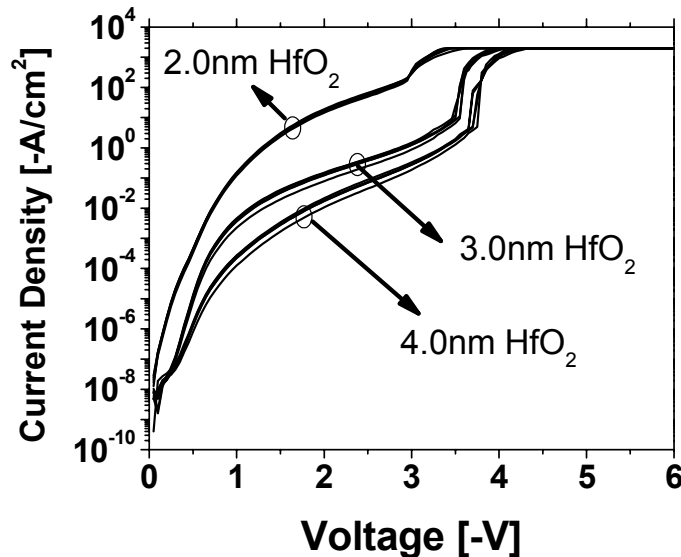
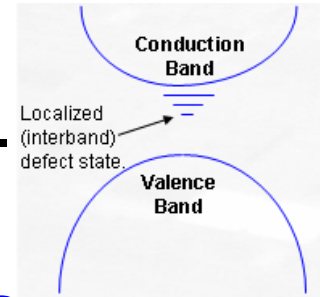

*P. D. Kirsch et al. J. Appl. Phys. 99, 023508 (2006)*

# Previous results:

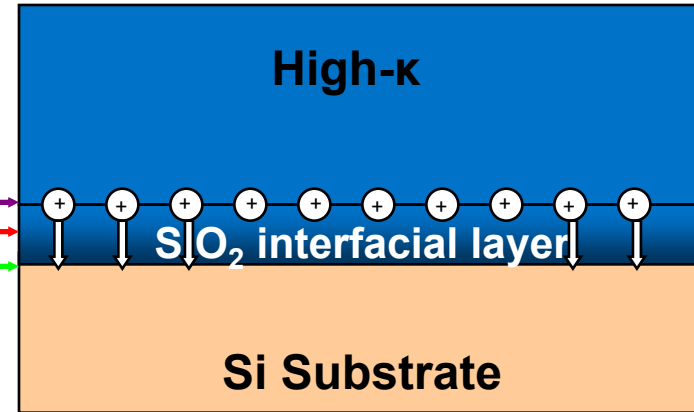
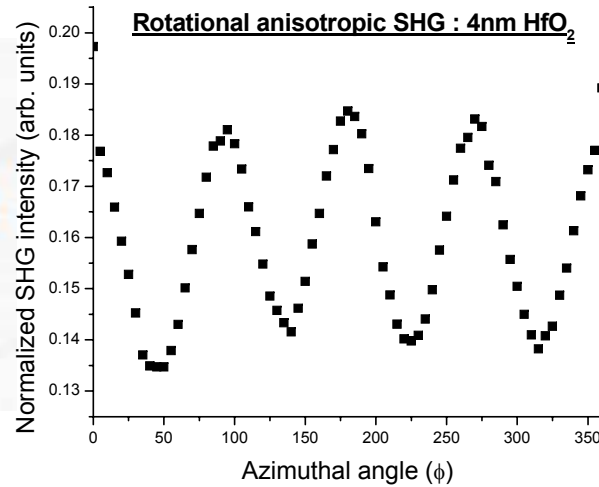
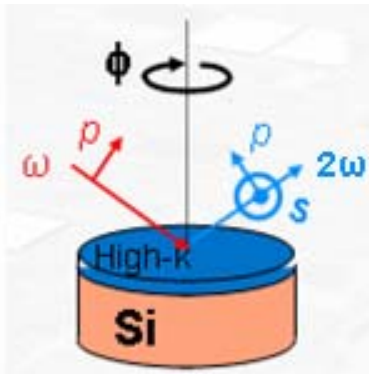

$$I_{PP}^{(2\omega)} = \left| a_0^{PP} + a_4^{PP} \cos(4\phi) \right|^2$$

- $a_4^{PP}$  is from silicon, but very weak

$$a_0^{PP} = \underbrace{a_0^{Si/SiO_2} + a_0^{SiO_2/High-k}}_0 + a_{EFISH}^{Si}$$

Previous work demonstrated these two coefficients are negligible.

- $\therefore a_{EFISH}^{Si} \neq 0$  (Dominant contribution)

Electric Field Induced Second Harmonic Generation (EFISH).

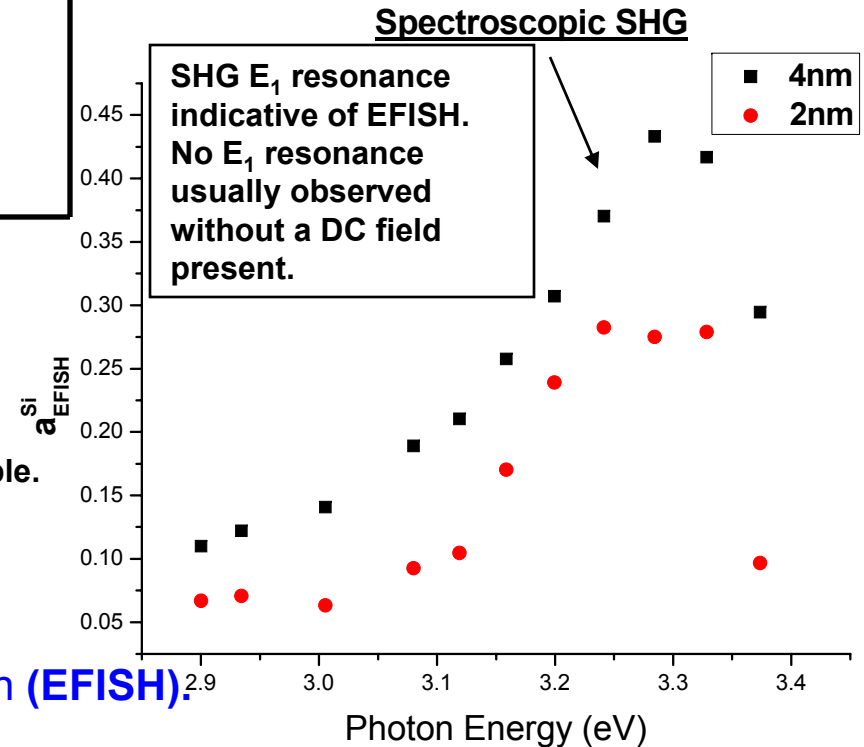

## Varying Composition:

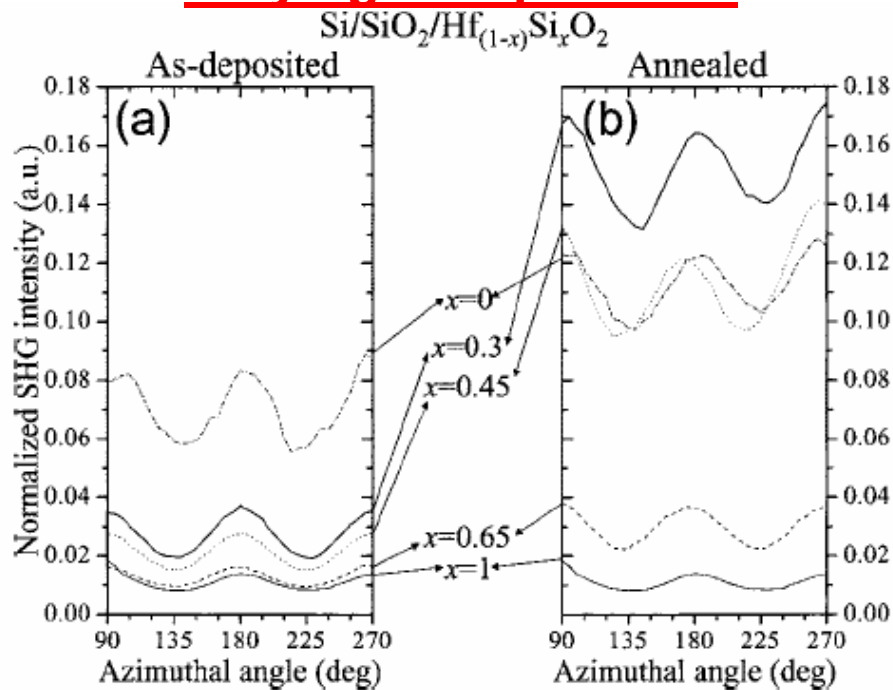

## Varying Anneal Temperature:

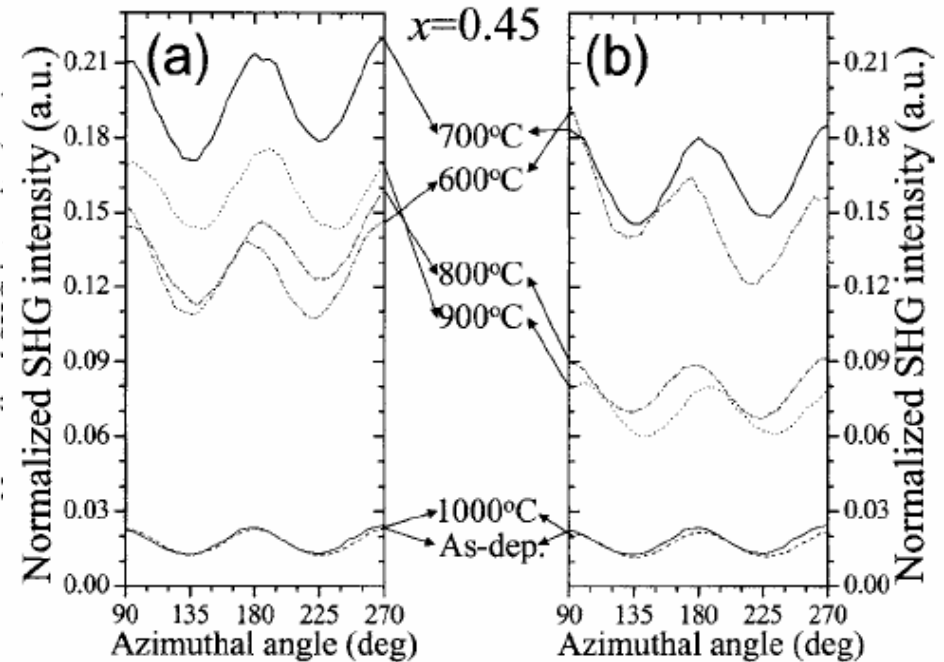

FIG. 3.  $p$ -in/ $p$ -out RA-SHG from samples with varying Si content  $x$ . (a) As-deposited samples. (b) Samples annealed at 700 °C for 60 s in 30 Torr ammonia. The azimuthal range has been reduced for brevity.

## What did we learn?

- Interfacial electrostatic fields are primary contribution to SHG response.
- These interfacial fields are modified by subtle film growth conditions (composition, anneal temperature, and thickness).
- Photo-excited charge carriers in the substrate, trapped in the dielectric defect centers, are the source of these DC field.

# SHG measurements:

• **Second Harmonic Generation:**  $P_i^{(2\omega)} = \chi_{ijk}^{(2)} E_j^{(\omega)} E_k^{(\omega)}$

• **Symmetry arguments govern SHG:**  $\chi_{ijk}^{(2),bulk} = 0$ ,  $\chi_{ijk}^{(2),surface} \neq 0$ ,  $\chi_{ijk}^{(2),EFISH} \neq 0$

• **TD-SHG:**  $I^{2\omega}(t) \propto |\chi^{(2)} + \chi^{(3)} E_{DC}(t)|^2 I^2(\omega)$

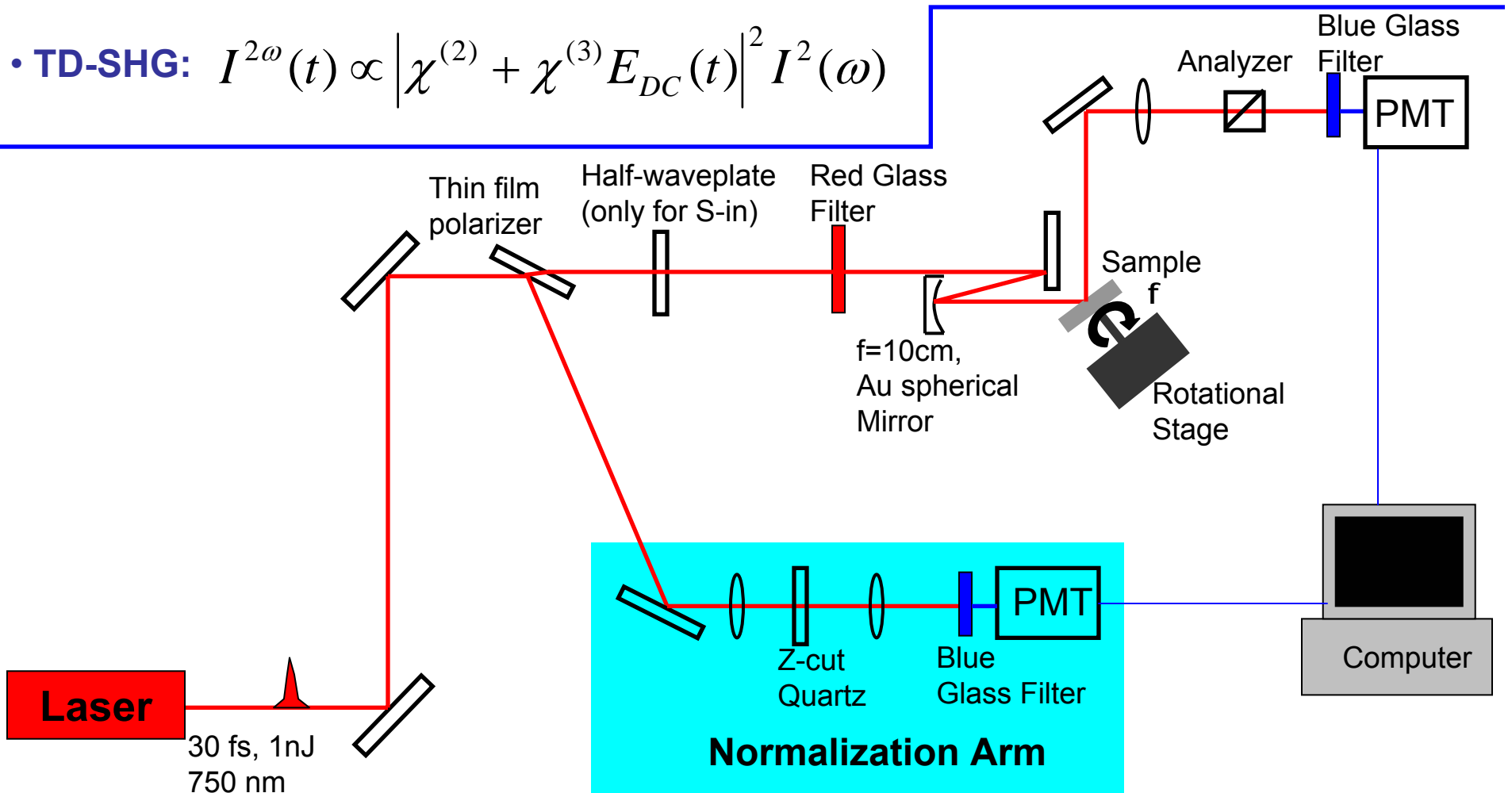

# Samples:

- HfO<sub>2</sub> deposited via Atomic Layer Deposition (ALD).
- Interfacial oxide thickness previously determined using HR-TEM.
- HfO<sub>2</sub> thickness verified using spectroscopic ellipsometry.
- Post Deposition and Rapid Thermal Anneals (PDA & RTA) performed *ex-situ*.

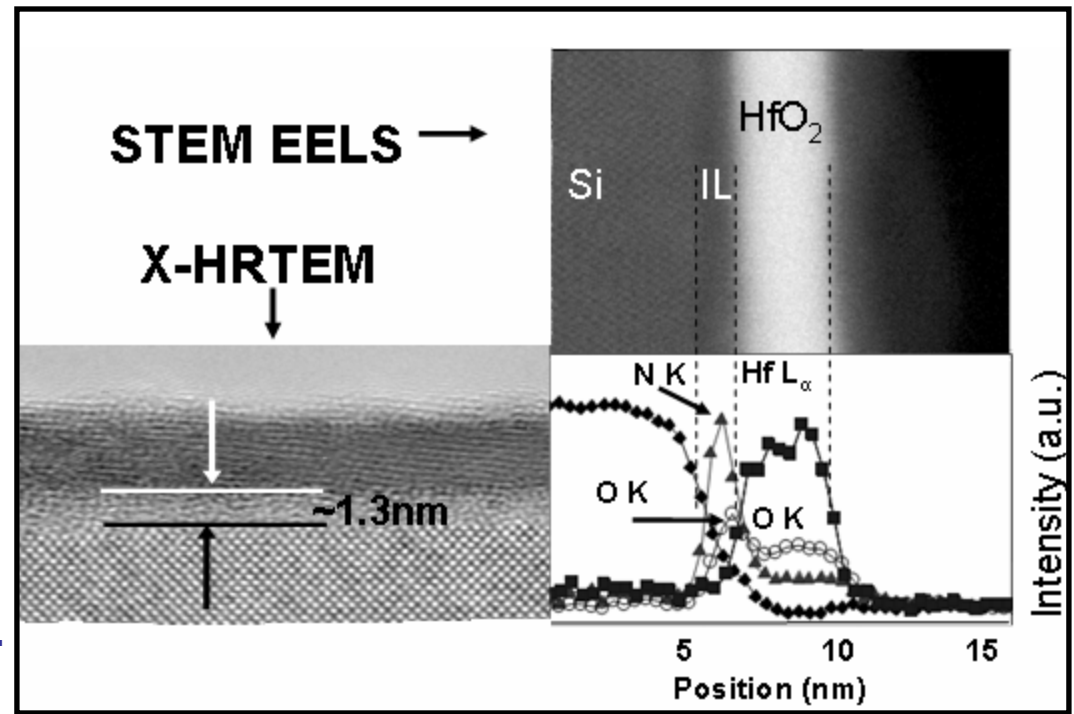

**Objective:** Investigate the evolution of HfO<sub>2</sub> crystallinity, bottom interfacial layer stoichiometry, and charge trap defect density as a function of thickness and anneal.

Substrate	Interface	High-k	Anneal
Si (100)	~1nm SiO <sub>2</sub>	2nm HfO <sub>2</sub>	As-deposited
Si (100)	~1nm SiO <sub>2</sub>	3nm HfO <sub>2</sub>	As-deposited
Si (100)	~1nm SiO <sub>2</sub>	4nm HfO <sub>2</sub>	As-deposited
Si (100)	~1nm SiO <sub>2</sub>	2nm HfO <sub>2</sub>	700C NH <sub>3</sub> PDA + 1000C N <sub>2</sub> RTA
Si (100)	~1nm SiO <sub>2</sub>	3nm HfO <sub>2</sub>	700C NH <sub>3</sub> PDA + 1000C N <sub>2</sub> RTA
Si (100)	~1nm SiO <sub>2</sub>	4nm HfO <sub>2</sub>	700C NH <sub>3</sub> PDA + 1000C N <sub>2</sub> RTA

# Anatomy of a time dependent SHG measurement:

## 3 possible charge transfer mechanisms:

### 1. Photo-excited electron injection:

- Si / SiO<sub>2</sub> band offsets = 4.3 eV. Therefore, 3 photon (hν = 1.6 eV) process necessary to inject electrons.

### 2. Photo-excited hole injection:

- Si / SiO<sub>2</sub> band offsets = 5.8 eV. Therefore, 4 photon (hν = 1.6 eV) process necessary to inject holes.

### 3. Trap-assisted resonant tunneling:

Electrons or holes can tunnel through ~ 1nm interfacial layer.

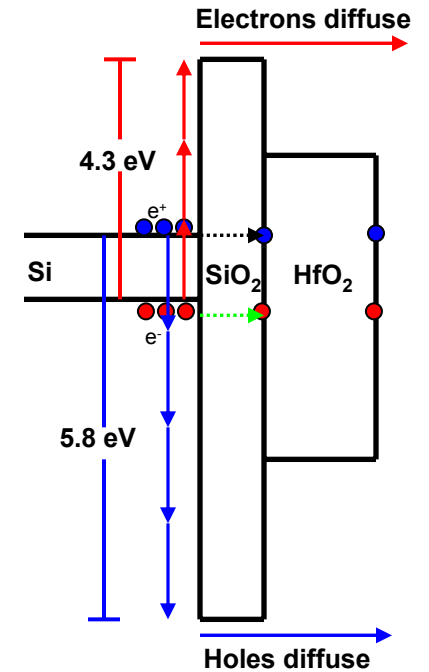

## E-field breaks translational symmetry and enhances SHG response

t = 0

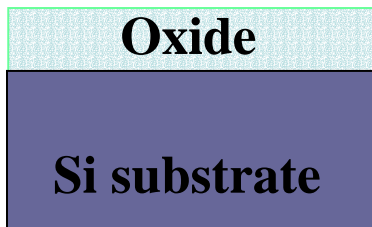

t > 0

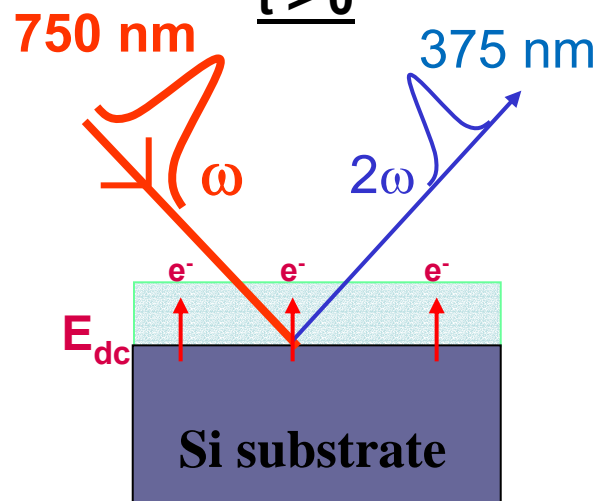

t >> 0

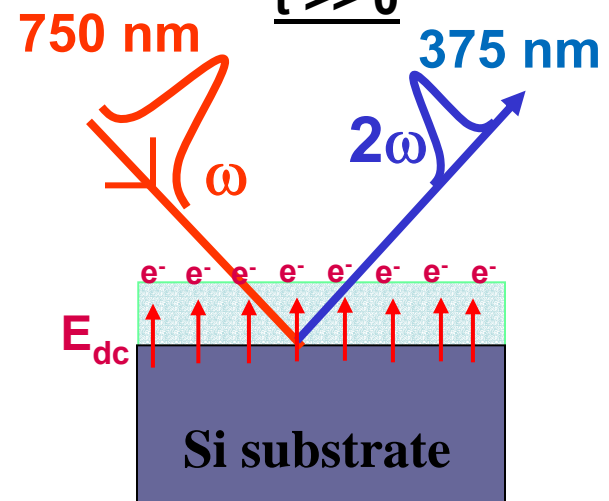

# Time Dependent SHG: As-deposited HfO<sub>2</sub>

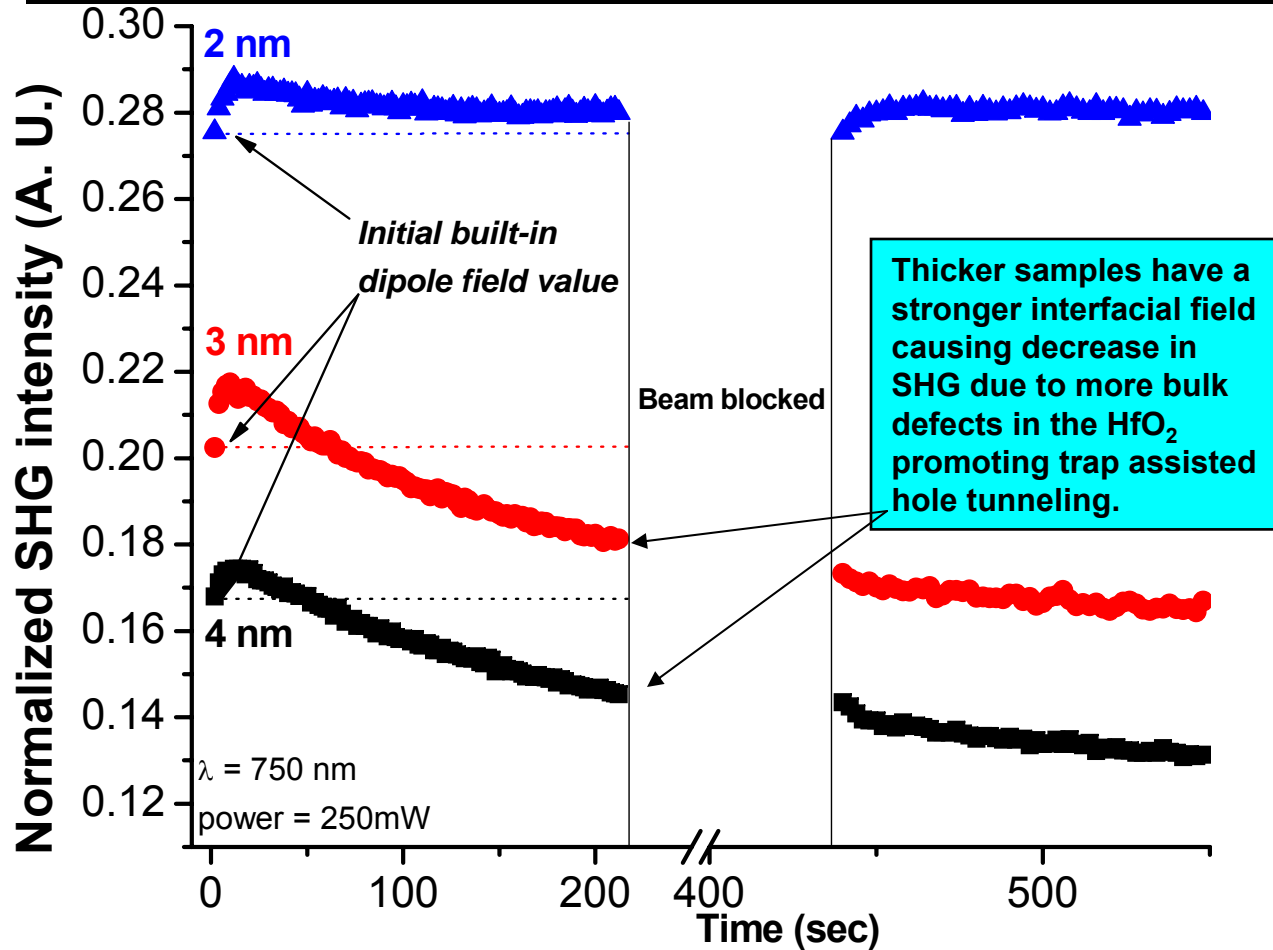

## SHG time evolution:

- **t < 15sec:** SHG increases due to photo-excited electrons creating a stronger interfacial electrostatic field.
- **t ~ 15sec:** SHG reaches a maxima due to competing electron/hole created fields equally opposing each other.
- **t > 15sec:** SHG decreases due to resonant tunneling hole carriers dominating the build up of interfacial fields.
- **t = 210-440sec:** dark period, system recovery.
- **t > 440sec:** 3nm and 4nm HfO<sub>2</sub> SHG signals still dominated by resonant hole tunneling dynamics. 2nm HfO<sub>2</sub> SHG signal increases due to photo-excited electron injection.

**t < 15**

**t ~ 15**

**t > 15**

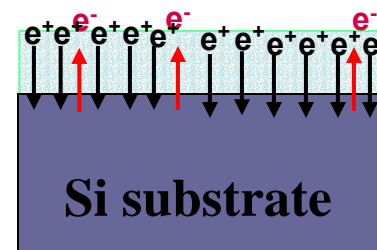
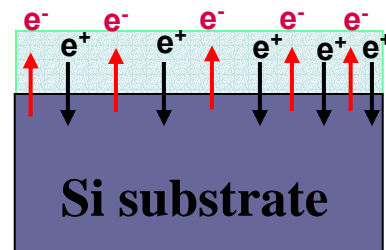
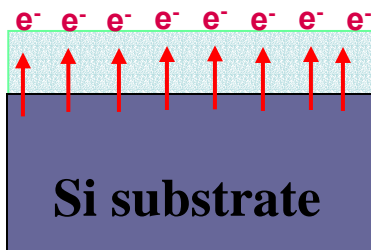

# Time Dependent SHG: annealed HfO<sub>2</sub>

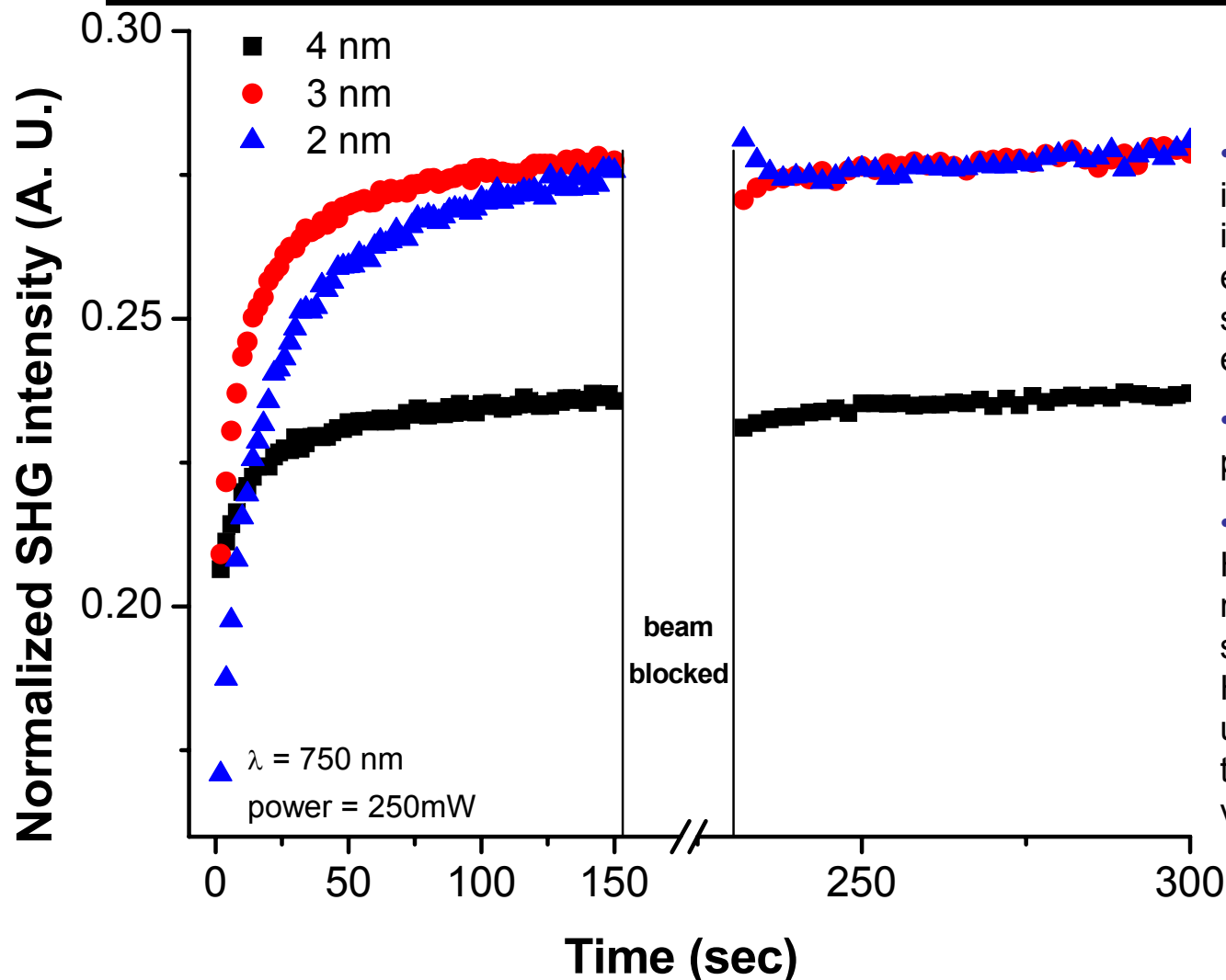

## SHG time evolution:

- t < 160sec: SHG increases to a saturated intensity value due to photo-excited electrons creating a stronger interfacial electrostatic field.
- t = 160-225sec: dark period, system recovery.
- t > 225sec: 3nm and 4nm HfO<sub>2</sub> SHG signals monotonically rise to a saturated intensity. 2nm HfO<sub>2</sub> SHG signal unexpectedly decreases to the same saturated intensity value.

No decrease in SHG is observed for the annealed samples, corresponding to reversal of the interfacial electrostatic field, presumably due to less bulk defects available to promote trap assisted hole tunneling. Therefore, dominant charge transfer mechanism is photo-excited electron transfer to the surface.

# Rotational Anisotropic SHG:

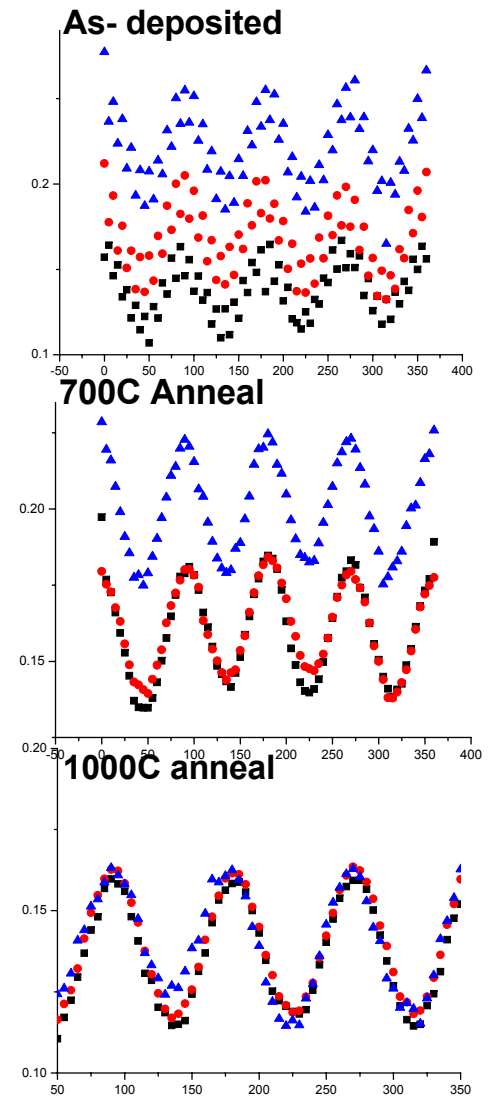
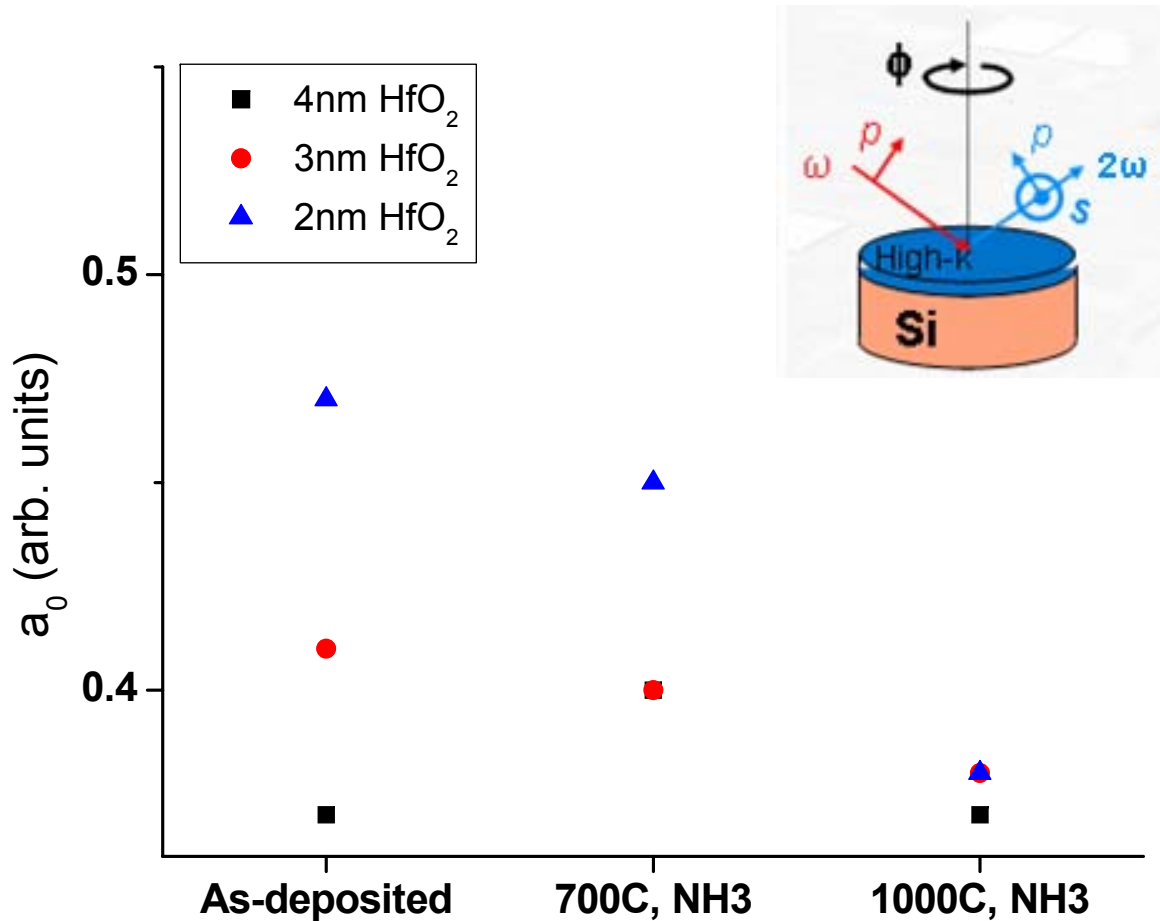

- Previous studies indicated dipolar coefficient's ( $a_0$ ) main contribution from EFISH.
- Except for the 4nm 700C sample,  $a_0$  trends inversely with temperature and thickness.
- RA-SHG results indicate that EFISH contribution from charge trap centers is sensitive to both changes in temperature and film thickness.

# Supporting optical measurements:

## • Sub- $E_g$ absorption (SE):

- Charge trapping centers for a dielectric lie within the bandgap.
- Measure sub-bandgap absorption with spectroscopic ellipsometry.
- Sub-bandgap absorption “density” decreases with  $\text{HfO}_2$  film thickness, suggesting less charge trapping centers.
- Must ignore Si critical point absorption sites @ 3.4eV, 4.25eV, and 5.2eV (Price et. al., Appl. Phys. Lett. 2007)

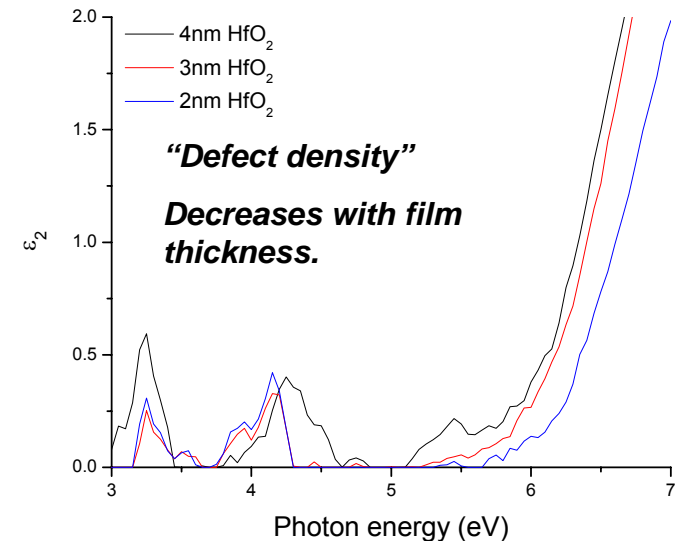

## • Grazing angle attenuated FTIR:

- Absorption stretch at  $\sim 1250\text{cm}^{-1}$  due to Si-O LO phonon mode.
- Since these films are  $\text{HfO}_2$  this absorption peak must originate from bottom oxide interfacial layer.
- Absorption strength increases with decreasing  $\text{HfO}_2$  thickness suggesting more stoichiometric bottom interfacial layer.

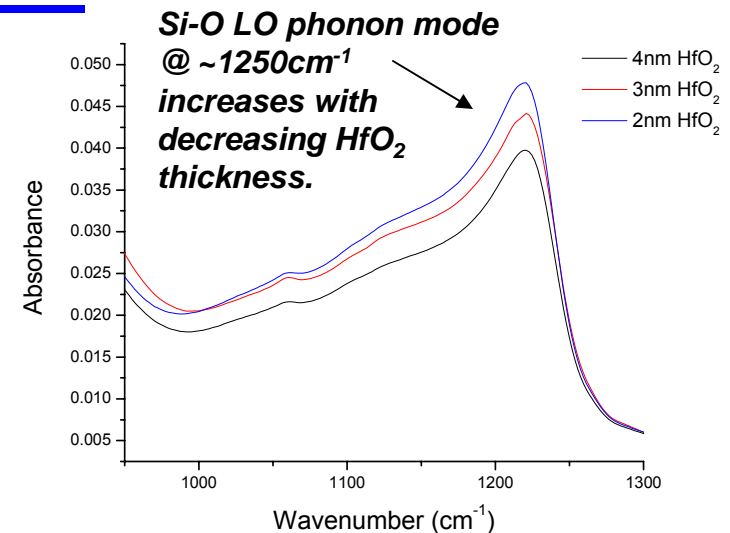

## **Conclusions:**

- **SHG demonstrates strong sensitivity towards process dependent changes in HfO<sub>2</sub> parameters such as thickness and anneal temperature.**
- **Observations of both electron and hole injection dynamics are observed for time dependent measurements.**
- **Trap-assisted hole tunneling dominates the TD-SHG response for as-deposited HfO<sub>2</sub> samples presumably due to a larger density of trapped charge centers in the dielectric promoting hole transfer.**
- **A qualitative understanding of the relative charge trap density and overall integrity of the dielectric film may be inferred from analysis of time dependent SHG dynamics.**

## **Acknowledgements:**

- **Pat Lysaght (SEMATECH)**
- **Gennadi Bersuker (SEMATECH)**